

TOP VIEW

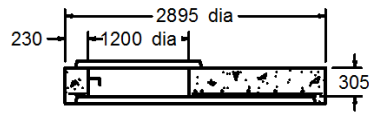

SECTION A-A
TRANSITION SLAB

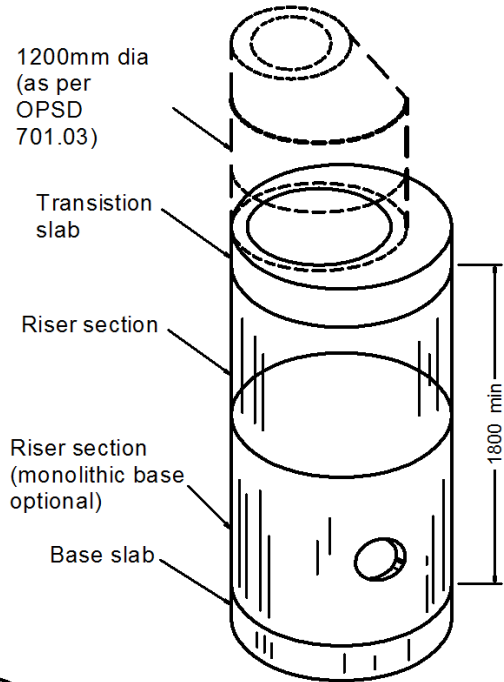

2400 to 1200mm Dia

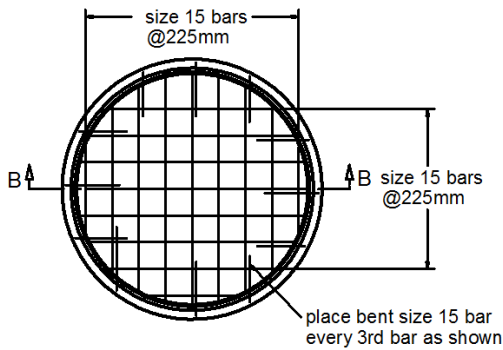

TOP VIEW

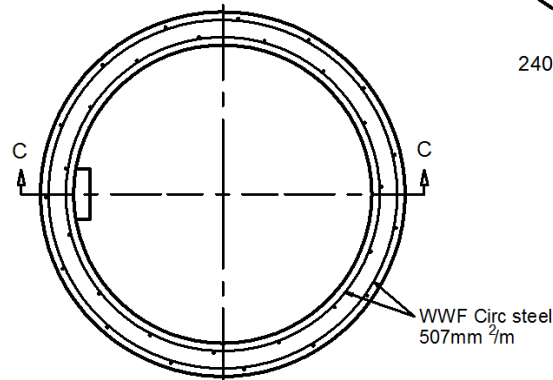

TOP VIEW

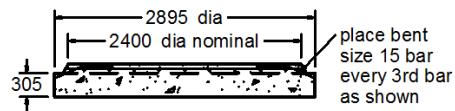

SECTION B-B
BASE SLAB

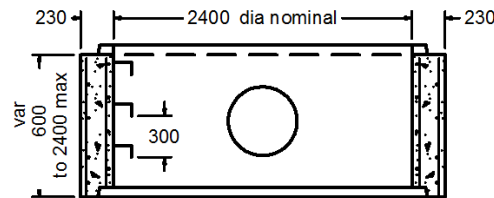

SECTION C-C
RISER SECTION

SPECIFICATIONS

ALL DIMENSIONS IN MILLIMETRES.

CONCRETE:

35 MPa @ 28 DAYS,
5-8% AIR ENTRAINMENT IN ACCORDANCE
WITH CSA A23.1 MOD-M90

REINFORCING:

IN ACCORDANCE WITH CSA G30.18 & OPSS 1440.
WELDED WIRE FABRIC TO CSA G30.5.
ALL REINFORCING STEEL HAS 30mm MIN. COVER.

NOTES:

MANUFACTURED IN ACCORDANCE WITH
OPSD 701.013, 701.060 AND 701.061.
MANUFACTURED IN ACCORDANCE WITH OPSS 1351.
DESIGNED TO OHBD CODE.
REINFORCING DETAILS AVAILABLE UPON REQUEST.

2400mm DIA CONCRETE MANHOLE (MH2400)



1645 SYDENHAM RD.
KINGSTON, ONT.

PHONE:
(800) 223-0012
1-613-546-6683

www.anchorconcrete.com