

TOP VIEW CHAMBER  
1:40

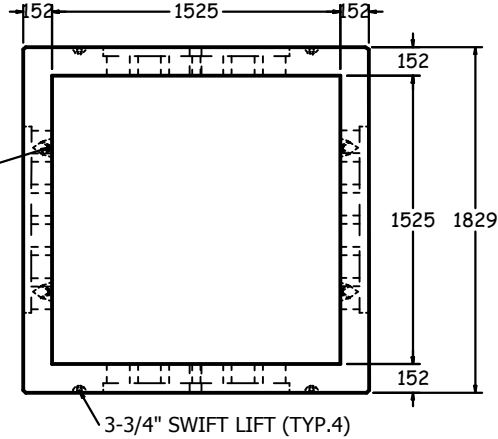

UTILITY ANCHOR  
(TYP.4)

3-3/4" SWIFT LIFT (TYP.4)

TOP VIEW LID  
1:40

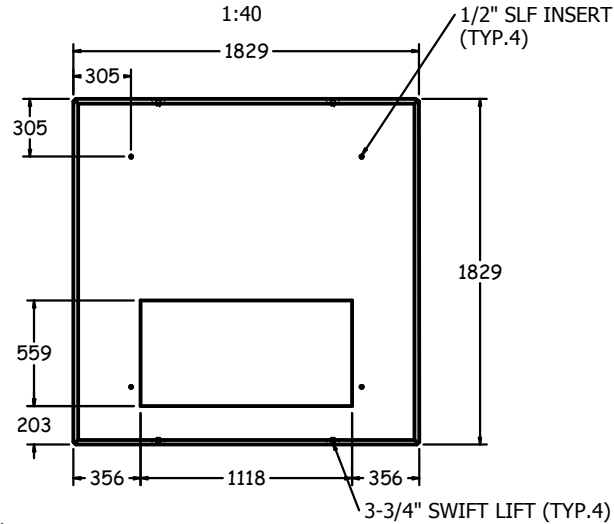

1/2" SLF INSERT  
(TYP.4)

3-3/4" SWIFT LIFT (TYP.4)

2-1/2" ROTATING HOLE (TYP.2)

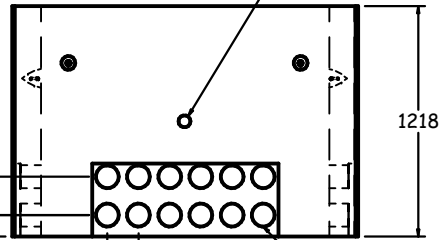

FRONT VIEW  
1:40

CABLE ENTRY PVC SEAL OPENINGS  
FOR MAX 4-3/4" I.D. DUCT (TYP. EACH SDIE)

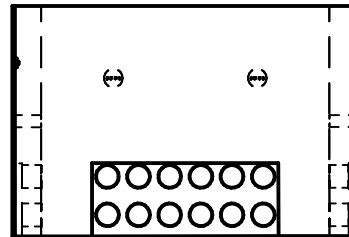

SIDE VIEW  
1:40

**ACP-114 VAULT (EL2000)**

**SPECIFICATIONS**

ALL DIMENSIONS IN MILLIMETRES.

**CONCRETE:**

35 MPa @ 28 DAYS,  
5-8% AIR ENTRAINMENT IN ACCORDANCE  
WITH CSA A23.1 MOD-M90.

**REINFORCING:**

IN ACCORDANCE WITH CSA G30.18 & OPSS 1440.  
ALL REINFORCING STEEL HAS 30mm MIN. COVER.

**WEIGHT:**

CHAMBER 2663 KG  
TOP SLAB 986 KG

**NOTES:**

REINFORCING DETAILS AVAILABLE UPON REQUEST.

SUITABLE FOR SINGLE PHASE TRANSFORMERS  
OR 4-WAY MINI-T SECTIONALIZERS.



1645 SYDENHAM RD.  
KINGSTON, ONT.

PHONE:  
(800) 223-0012  
1-613-546-6683

[www.anchorconcrete.com](http://www.anchorconcrete.com)