

OPTIONS AVAILABLE UPON REQUEST INCLUDE:

- DUCT TERMINATORS
- SUMP W/DRAIN
- CAST-IN PULLING EYES
- CAST-IN CABLE RACKS
- CAST IRON EMBOSSED W/ ELECTRICAL OR COMMUNICATION

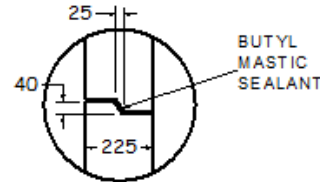

JOINT CROSS SECTION

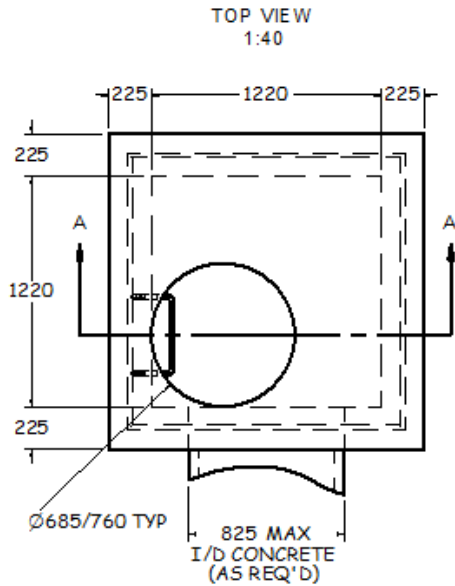
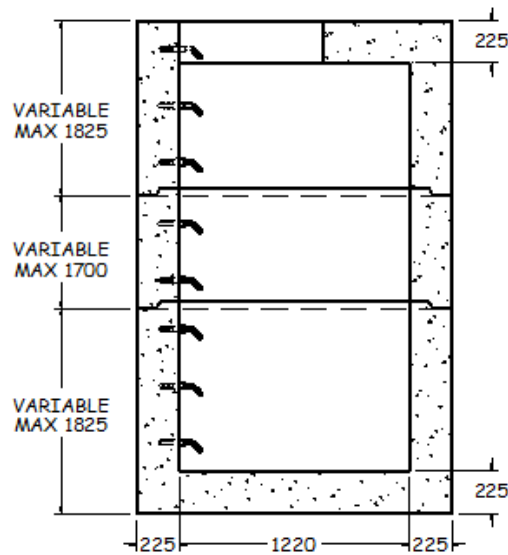

SECTION A-A
1:40

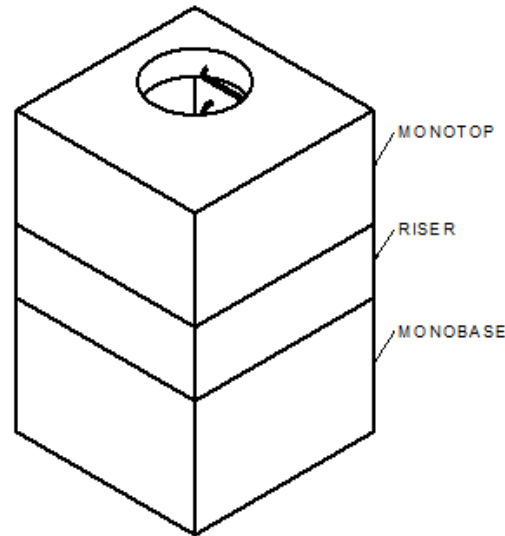

ISOMETRIC VIEW
1:50

1220x1220 ELECTRICAL/COMMUNICATION MANHOLE (BM1200)

SPECIFICATIONS

ALL DIMENSIONS IN MILLIMETRES.

CONCRETE:

45 MPa @ 28 DAYS,
5-8% AIR ENTRAINMENT IN ACCORDANCE
WITH CSA A23.1 MOD-M90.

REINFORCING:

IN ACCORDANCE WITH CSA G30.18 & OPSS 1440.
ALL REINFORCING STEEL HAS 30mm MIN. COVER.

WEIGHT:

WALLS	-3122 KG/V.M.
MONO BASE/TOP	-804 KG
TOP SLAB	-1506 KG

NOTES:

- PRODUCT MANUFACTURED TO C.H.B.D.C. LOADING.
- MANUFACTURED IN ACCORDANCE WITH OPSS 1351.
- REINFORCING DETAILS AVAILABLE UPON REQUEST.
- ALL PIECES INCLUDE SWIFT LIFT LIFTING ANCHORS.

ALL MAINTENANCE HOLES INCLUDE
SOLID ALUMINUM LADDER RUNGS
AS PER OPSD 405.020.

VARIABLE OPENINGS IN TOP SLAB
AVAILABLE UPON REQUEST.

MAX. BURIAL DEPTH: 900mm.
DEEP BURIAL DEPTHS AVAILABLE UPON REQUEST.

REFER TO DRAWING MH-3 FOR MAX. PIPE SIZES.
PIPE GASKETS AVAILABLE UPON REQUEST.

REFER TO INSTALLATION GUIDELINES
FOR BOX MANHOLES AND CHAMBERS.



1645 SYDENHAM RD.
KINGSTON, ONT.

PHONE:
(800) 223-0012
1-613-546-6683

www.anchorconcrete.com