

OPTIONS AVAILABLE UPON REQUEST INCLUDE:

DUCT TERMINATORS
SUMP W/DRAIN
CAST-IN PULLING EYES
CAST-IN CABLE RACKS
CAST IRON EMBOSSED W/ ELECTRICAL OR COMMUNICATION

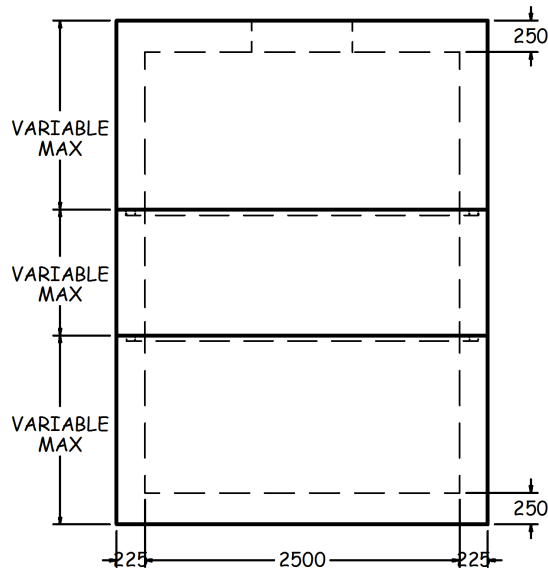

SECTION A-A
1:60

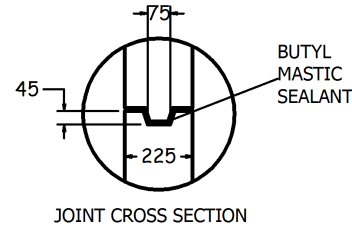
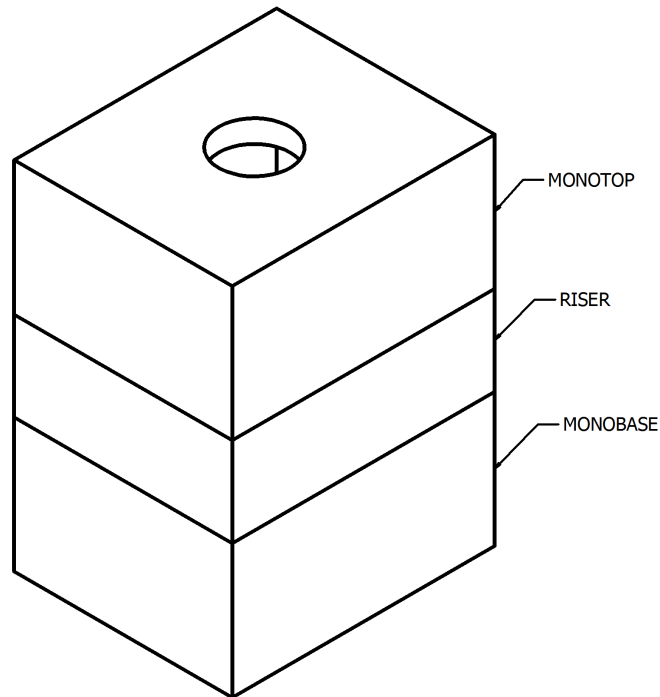

ISOMETRIC VIEW
1:60

SPECIFICATIONS

ALL DIMENSIONS IN MILLIMETRES.

CONCRETE:

45 MPa @ 28 DAYS,
5-8% AIR ENTRAINMENT IN ACCORDANCE
WITH CSA A23.1 MOD-M90.

REINFORCING:

IN ACCORDANCE WITH CSA G30.18 & OPSS 1440.
ALL REINFORCING STEEL HAS 30mm MIN. COVER.

WEIGHT:

WALLS	-5350 KG/V.M.
MONO BASE/TOP	-2700 KG
TOP SLAB	-3903 KG

NOTES:

PRODUCT MANUFACTURED TO C.H.B.D.C. LOADING.
MANUFACTURED IN ACCORDANCE WITH OPSS 1351.
REINFORCING DETAILS AVAILABLE UPON REQUEST.
ALL PIECES INCLUDE SWIFT LIFT LIFTING ANCHORS.

ALL MAINTENANCE HOLES INCLUDE
SOLID ALUMINUM LADDER RUNGS
AS PER OPSD 405.020.

VARIABLE OPENINGS IN TOP SLAB
AVAILABLE UPON REQUEST.

MAX. BURIAL DEPTH: 900mm.
DEEP BURIAL DEPTHS AVAILABLE UPON REQUEST.

REFER TO INSTALLATION GUIDELINES
FOR BOX MANHOLES AND CHAMBERS.

2000x2500 ELECTRICAL/COMMUNICATION MANHOLE



1645 SYDENHAM RD.
KINGSTON, ONT.

PHONE:
(800) 223-0012
1-613-546-6683

www.anchorconcrete.com