

SECTION VIEW
1:20

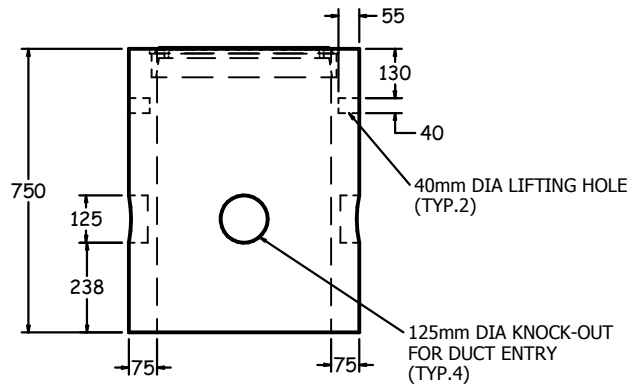

FRONT VIEW
1:20

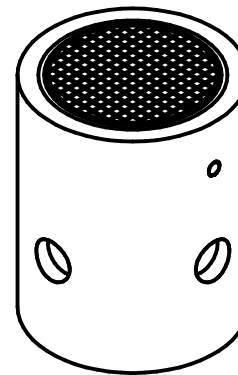

ISOMETRIC VIEW
1:20

SPECIFICATIONS

ALL DIMENSIONS IN MILLIMETRES.

CONCRETE:

45 MPa @ 28 DAYS,
6% AIR ENTRAINMENT IN ACCORDANCE
WITH CSA A23.1 MOD-M90.

REINFORCING:

IN ACCORDANCE WITH CSA G30.18 & OPSS 1440.
ALL REINFORCING STEEL HAS 30mm MIN. COVER.

WEIGHT:

240 KG

NOTES:

MANUFACTURED IN ACCORDANCE WITH
OPSD 2112.020.

REINFORCING DETAILS AVAILABLE UPON REQUEST.

ALSO AVAILABLE IN 900mm AND 1100mm HIGH.

460mm DIA. ELECTRICAL HANDHOLE, WITH STD COVER (EL1000)



1645 SYDENHAM RD.
KINGSTON, ONT.

PHONE:
(800) 223-0012
1-613-546-6683

www.anchorconcrete.com