

TOP VIEW

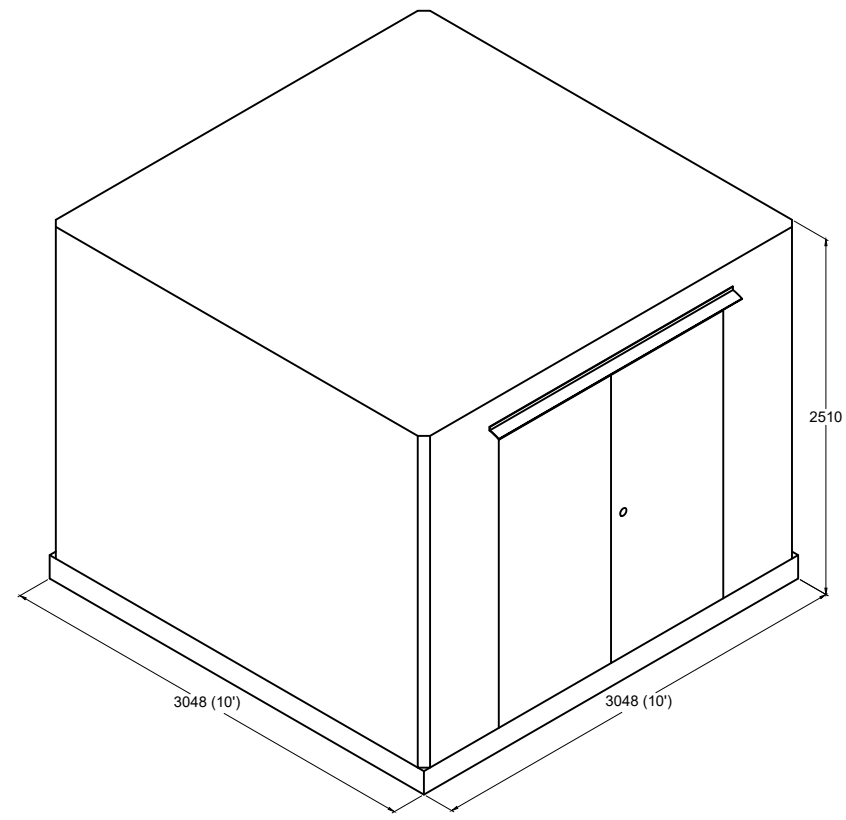

ISOMETRIC VIEW

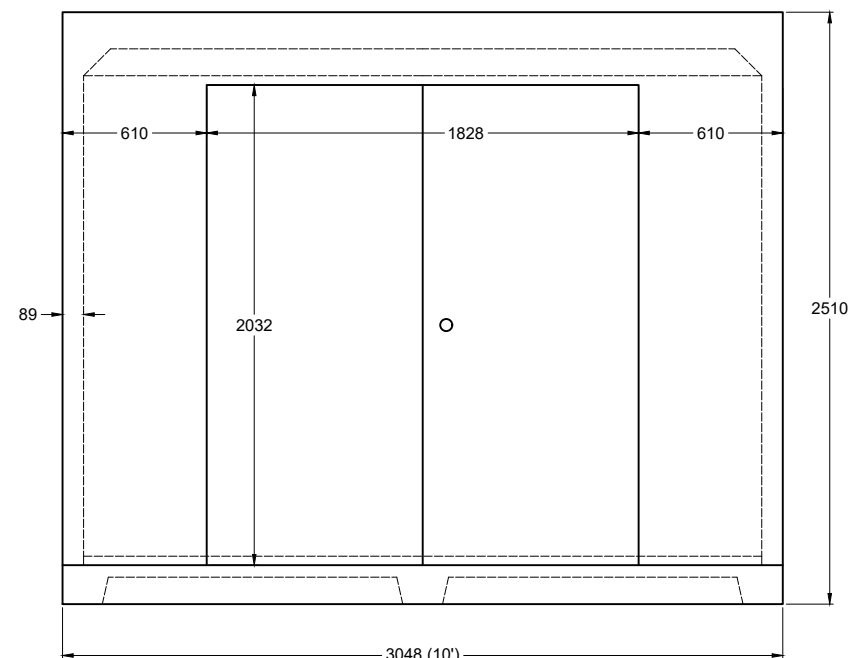

FRONT VIEW

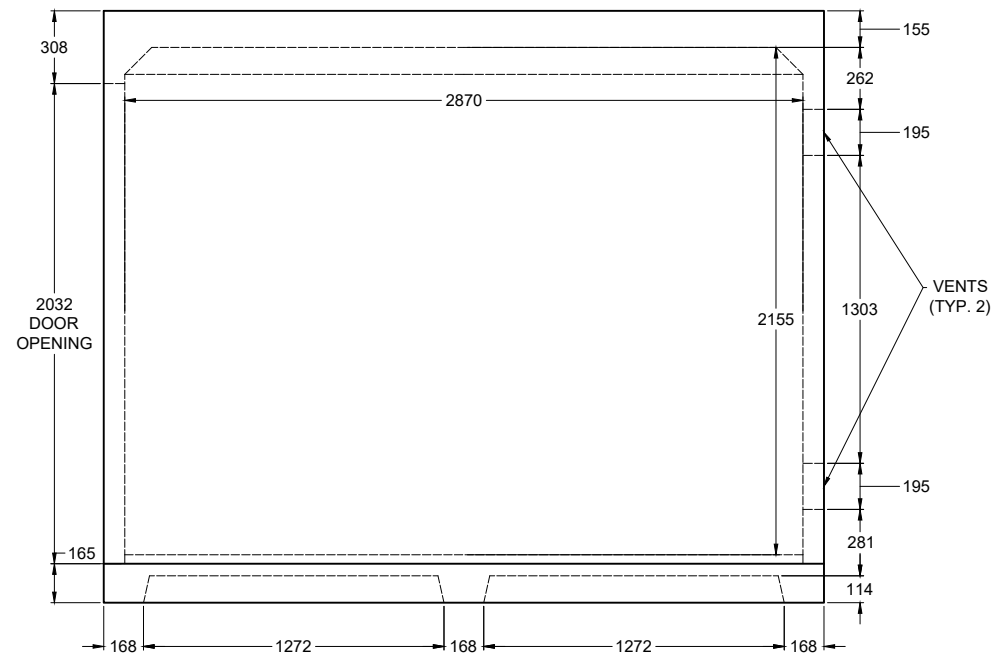

SIDE VIEW

**NOTES:**

ALL DIMENSIONS IN MILLIMETERS. UNLESS OTHERWISE SPECIFIED.

NOT TO SCALE

WEIGHT: 12 TONNES

THIS STRUCTURE HAS BEEN DESIGNED TO SUPPORT LOADS SPECIFIED IN THE N.B.C.C 2015

STEEL REINFORCED WALLS, ROOF, AND BASE

DELIVERED AND PLACED AS ONE PIECE, INSTALLATION BY CRANE AVAILABLE UPON REQUEST

INSTALL BUILDING ON PREPARED BASE (BY OTHERS)

PRODUCED WITHOUT A JOINT IN BETWEEN THE ROOF AND WALLS FOR SUPERIOR WEATHER PROTECTION

EXPOSED AGGREGATE FINISH

CONTAINS TWO WEATHER RESISTANT ALUMINUM VENTS

COATED WITH GRAFFITI GUARD

STEEL DOORS INCLUDE HIGH QUALITY DEADBOLT LOCK, FINGER PULL, ASTRAGAL, SPRING-SOFTENED CHAIN CHECKS, DOOR SWEEP, AND RAIN DRIP EDGE

NON-ACTIVE DOOR INCLUDES TOP AND BOTTOM PAD BOLTS

ANCHOR CONCRETE PRODUCTS LTD. ASSUMES NO LIABILITY FOR ANY SITE CONDITIONS. ALL DETAILS RELATED TO STABILITY OF FOUNDING CONDITIONS, EXCAVATIONS DEWATERING, BACKFILL, GEOMETRY, AND ASSOCIATED WORKS ARE THE SOLE RESPONSIBILITY OF THE GENERAL CONTRACTOR AND OR OWNER. A QUALIFIED GEOTECHNICAL ENGINEER IS TO BE RETAINED TO ASSESS SITE CONDITIONS AND VERIFY FOUNDING CONDITIONS.

ALL LIFTING ANCHORS ARE TO BE DAYTON SUPERIOR OR APPROVED ALTERNATIVE. ALL RIGGING, HOISTING, AND LIFTING TO BE IN STRICT ACCORDANCE WITH DAYTON SUPERIOR MANUAL.

**SPECIFICATIONS:**  
PRODUCT DESIGNED IN ACCORDANCE WITH CSA A23.3

**PRODUCTION:**  
IN ACCORDANCE WITH CSA A23.4

**CONCRETE:**  
IN ACCORDANCE WITH CSA A23.1  
EXPOSURE CLASS: C1, 28 DAY COMP. STRENGTH: 35MPA, AIR ENTRAINMENT 5-8%

**REINFORCING:**  
IN ACCORDANCE WITH WITH CSA G30.18

# REDICAST 10 SERVICE BUILDING

DRAWN BY:  
JS

DATE:  
AUG 2023



1645 SYDENHAM RD.  
KINGSTON, ON

PHONE:  
(800) 223-0012  
1-613-546-6683

WWW.ANCHORCONCRETE.COM