

8" PARKING BUMPER
 203 x 2438 x 152
 (8" x 96" x 6")
 155kg ea.

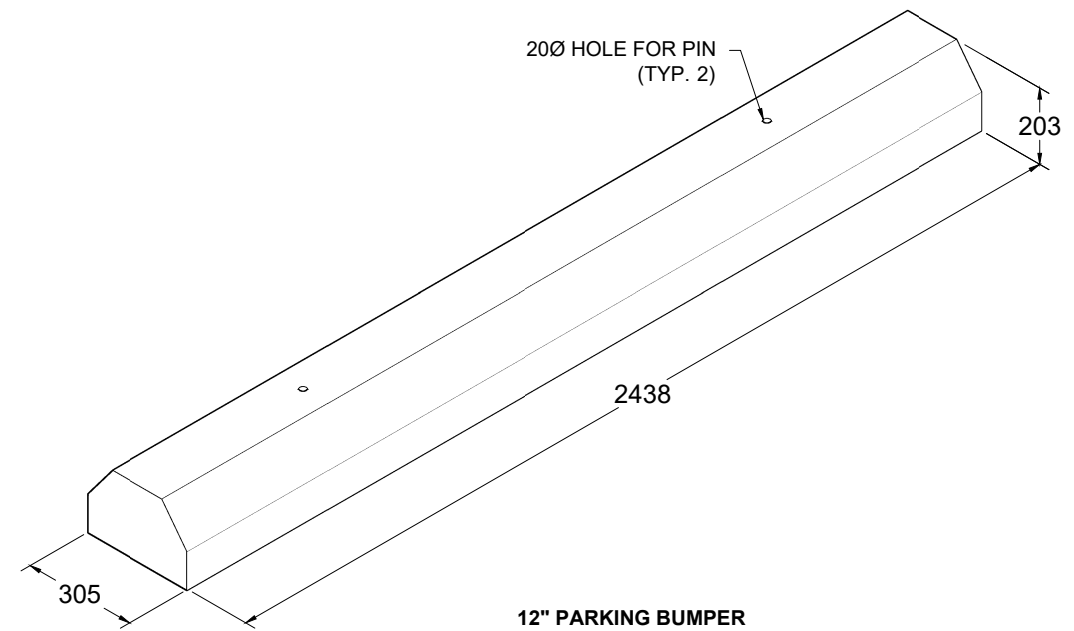

12" PARKING BUMPER
 305 x 2438 x 203
 (12" x 96" x 8")
 317kg ea.

SPECIFICATIONS:
 PRODUCT DESIGNED IN ACCORDANCE WITH CSA A23.3

PRODUCTION:
 IN ACCORDANCE WITH CSA A23.4

CONCRETE:
 IN ACCORDANCE WITH CSA A23.1
 28 DAY COMP. STRENGTH: 35MPA, AIR ENTRAINMENT 5-8%

REINFORCING:
 IN ACCORDANCE WITH WITH CSA G30.18
 GRADE 400W

PARKING BUMPERS



1645 SYDENHAM RD.
 KINGSTON, ON

PHONE:
 (800) 223-0012
 1-613-546-6683

WWW.ANCHORCONCRETE.COM